

Instruction for FEDOUR Filters

Internal Multi-functional Aquarium Submersible Filter

Warning

Before first use, please read this instruction manual and be familiar with the product. To use the product correctly and safely, be sure to follow the relevant safety instructions.

For safety, children and young people under the age of 18 are not allowed to use this product, as well as those who cannot identify the danger.

1. Note:

- 1) The product must work within the specified voltage and frequency range.
- 2) Do not let the product idling for more than 5 minutes, otherwise it will cause permanent damage to the filter pump.
- 3) This product can only be used in fresh water or sea water. Do not use it in flammable liquids, in acidic liquids or in corrosive liquids.
- 4) Do not lift the product directly with the power cord, otherwise the power cord may be broken.
- 5) If the power cord is damaged, please do not continue to use this product to ensure safety.

2. Maintain:

- 1) Before maintain, the power plug of all equipments in the water should be cut off.
- 2) Cleaning method: first take apart the product, and then remove the rotor and water leaves. Then put the pump head and related parts in clean water and slowly brush them with a soft brush. After the cleaning is completed, install the product according to the installation instructions.

3. Troubleshooting:

Trouble	Reason	Action
Being Noisy	<ul style="list-style-type: none">• Some air in the filter	<ul style="list-style-type: none">• Put the filter completely in the water in the opposite direction, wait for about 30 seconds, then slowly move to the normal direction so that the air can be fully expelled

Unable to start	<ul style="list-style-type: none"> No supply voltage Pump main unit burned down 	<ul style="list-style-type: none"> Check the supply voltage Replace the main unit
Not pump water Or pump little water	<ul style="list-style-type: none"> Rotor water leaf stuck The inlet or outlet is blocked 	<ul style="list-style-type: none"> Cleaning the rotor water leaf Clean the inlet or outlet
Pump shuts down after a short time	<ul style="list-style-type: none"> Severe turbid water The water temperature is too high 	<ul style="list-style-type: none"> Replace or clean water The maximum water temperature is 35°C

Warning: Please keep this product away from children under 18 years old.

Manufacturer: Zhongshan Ibay Electric Appliance Co., Ltd

Manufacturer Address: 3rd, No.6 Shunmin Road, Jixi Xiaolan Town, Zhongshan, Guangdong, China

E-mail: aquaservice@163.com aquaservice@yeah.net

We will be always on your service!

4. Disassemble Instruction

4:Disassemble Instruction

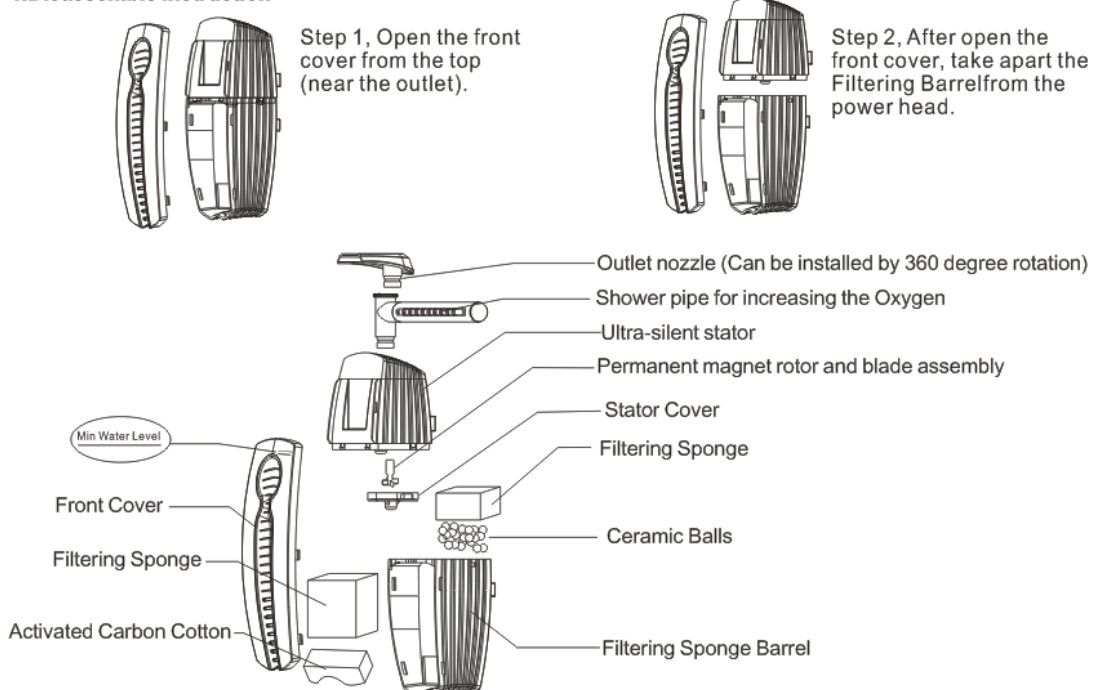

Notice: For some model, there are some small ceramic balls inside, it is easy to spill out when opening the filtering barrel, so we suggest you use a vessel or bag to avoid the ceramic balls Sprinkle all over the floor.

5. Installation Instruction



*The Min water level mark need to immerse into the water, We suggest to fit the filter under water as much as you can.

- 1, The Min water level mark need to immerse into the water, we suggest to fit the filter under water as much as you can, just leave the shower pipe or outlet nozzle out of water.
- 2, When you use shower pipe, you can adjust the water flow with the knob on the shower pipe.
- 3, Please install the cable as a dripping ring to prevent water flowing to the power socket along the cable. That is to say the tower end of the cable should be lower than the socket height, to avoid water backflow into the socket to cause an accident.

Warranty

From the date of purchase, non-human failure, in addition to the damage of the parts, this product is guaranteed a warranty. For details of the warranty period, please refer to the sales details page of this product. The following conditions and terms are not covered by the warranty:

- 1) Man-made failure, damage caused by installation errors, placement, and movement, causing irreparable damage to the product.
- 2) No reliable proof of purchase.
- 3) Failure caused by improper repair by the user
- 4) Failure caused by non-rated power(voltage and frequency).
- 5) When the product has quality problems, please contact the merchant in time. You can send us the product image through the above email address. When the confirmation is due to the loss caused by the product quality, we will provide you with warranty service, the maximum compensation does not exceed the product value of itself.
- 6) When using our products, please use the relevant products of our factory, or the products whose parameters match the products. Otherwise, we will not be responsible for the losses caused.